

# RACKPAK SETUP INSTRUCTIONS

VERSION 2020-06-16

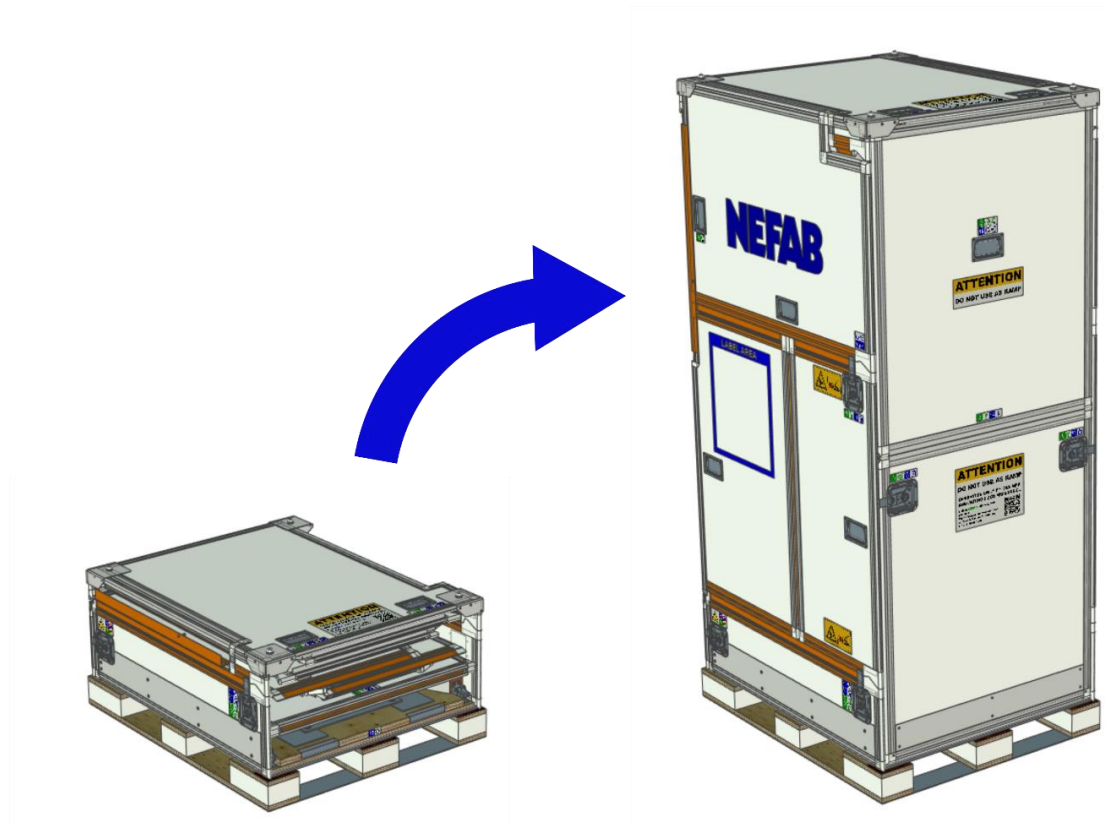

# RACKPAK SETUP INSTRUCTIONS



## REQUIRED PEOPLE AND EQUIPMENT

- This job requires two people
- Use steel-toe safety boots
- No tools needed

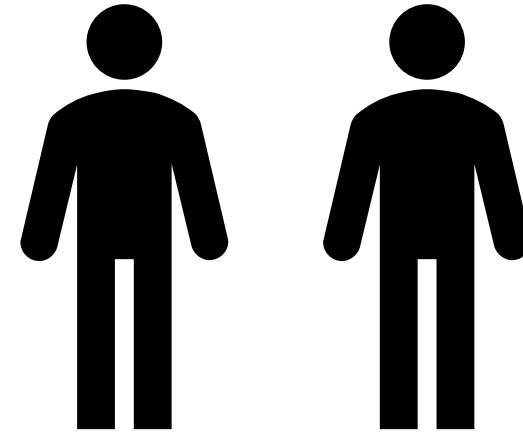

# RACKPAK SETUP INSTRUCTIONS



## REQUIRED SPACE

- 1.5 meter in front of product
- 2.0 meter behind product
- 1.0 meter on either side of product

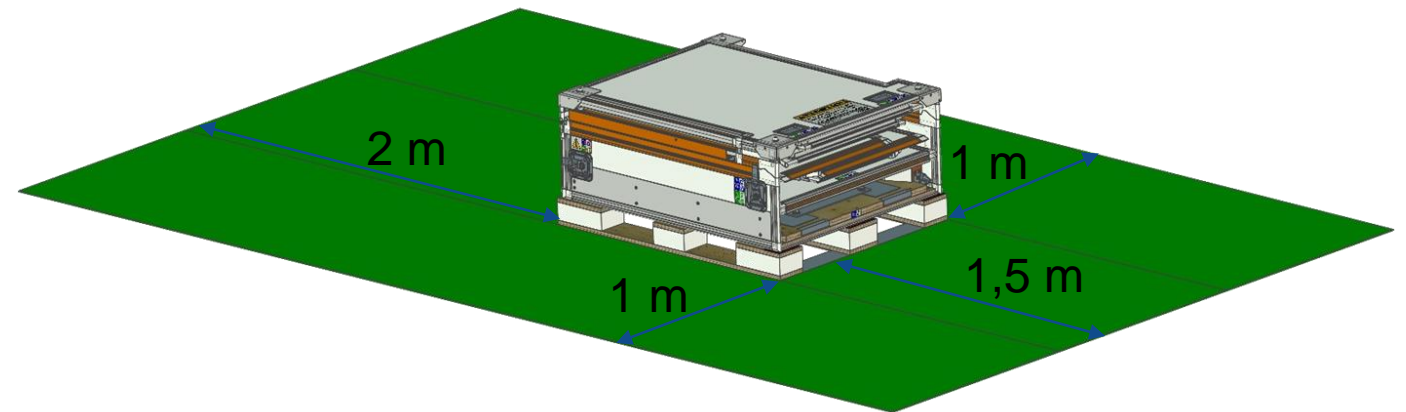

# RACKPAK SETUP INSTRUCTIONS



## REQUIRED SPACE

- 3.0 meter ceiling height

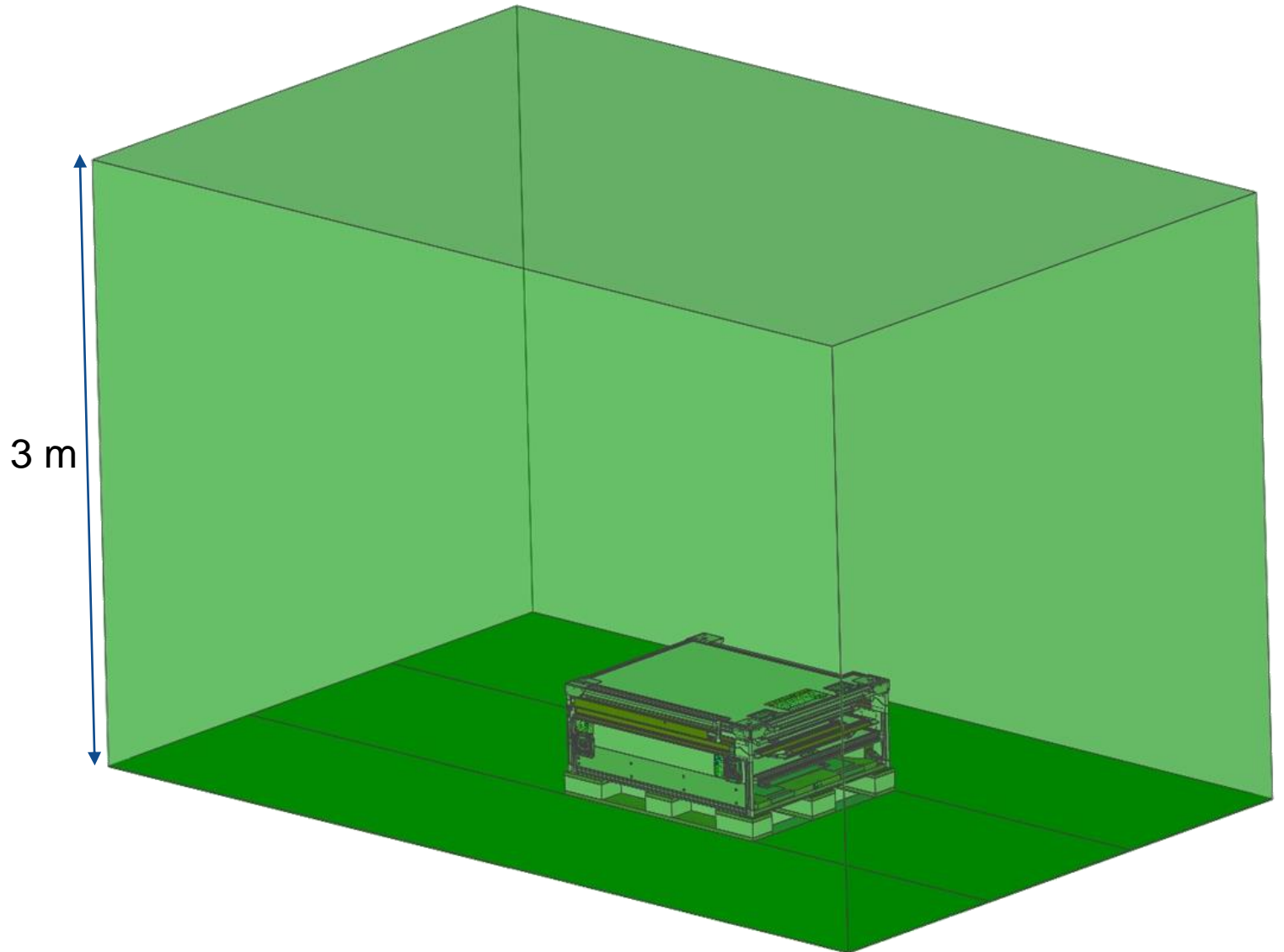

# RACKPAK SETUP INSTRUCTIONS



## SAFETY WARNINGS

- Use handles where provided to set up product
- While unfolding the product, do not place your hands where they may get pinched.

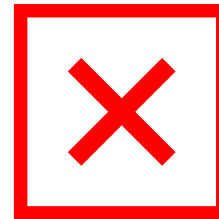

# RACKPAK SETUP INSTRUCTIONS



## SAFETY WARNINGS

- When opening latches, make sure to fold back the arm and buckle completely.

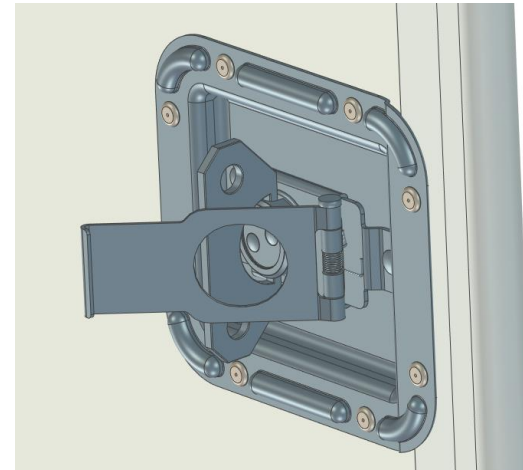
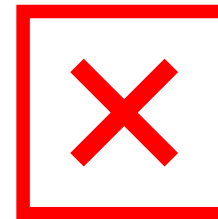
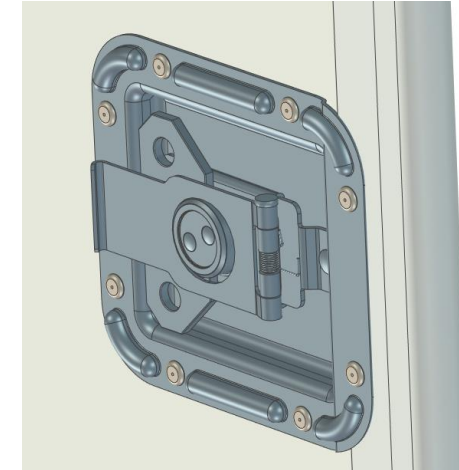

# RACKPAK SETUP INSTRUCTIONS



## SAFETY WARNINGS

- Under no circumstances use the front door as a ramp.

The contents of the crate must be unloaded using a stand-alone wood ramp, or Nefab's Rack Jack mobile hydraulic lifting platform.

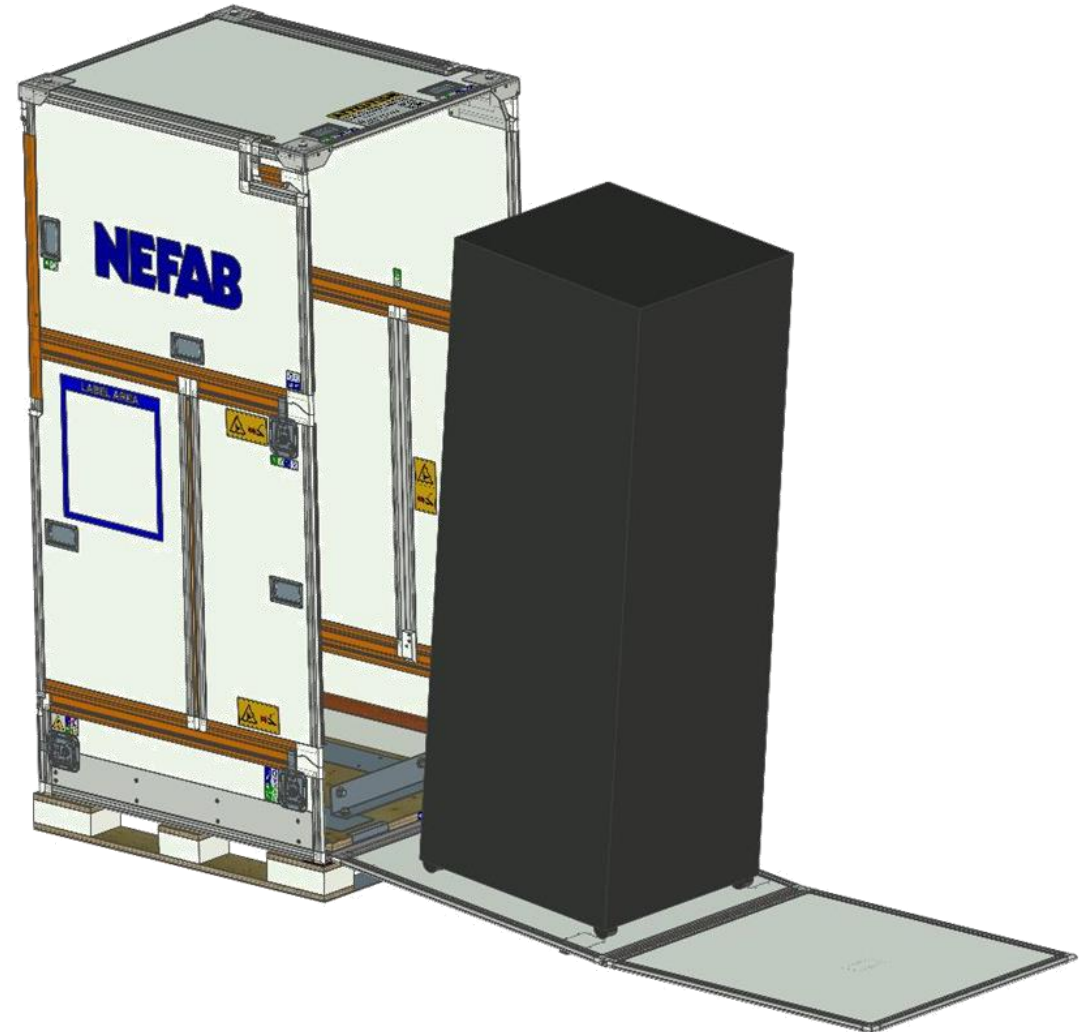
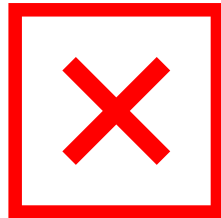

# RACKPAK SETUP INSTRUCTIONS



## SAFETY WARNINGS

In order to set up the product, follow the following steps.

These are marked with **BLUE** numbered labels on the product.



Double digit labels mean that you should do an action twice, on both sides of the product.

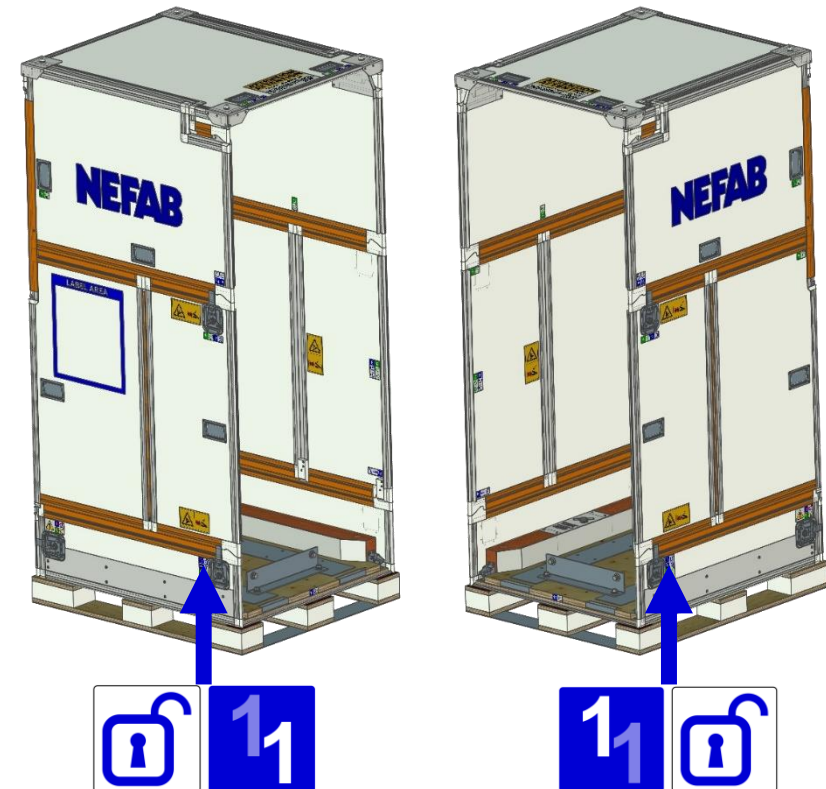



# 1

## RACKPAK SETUP INSTRUCTIONS

NEFAB

Open **front side latches** on both sides of product.

Do not open **rear side latches**!

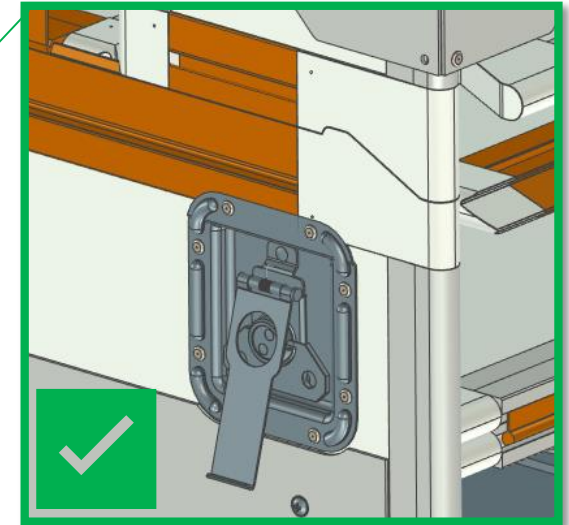
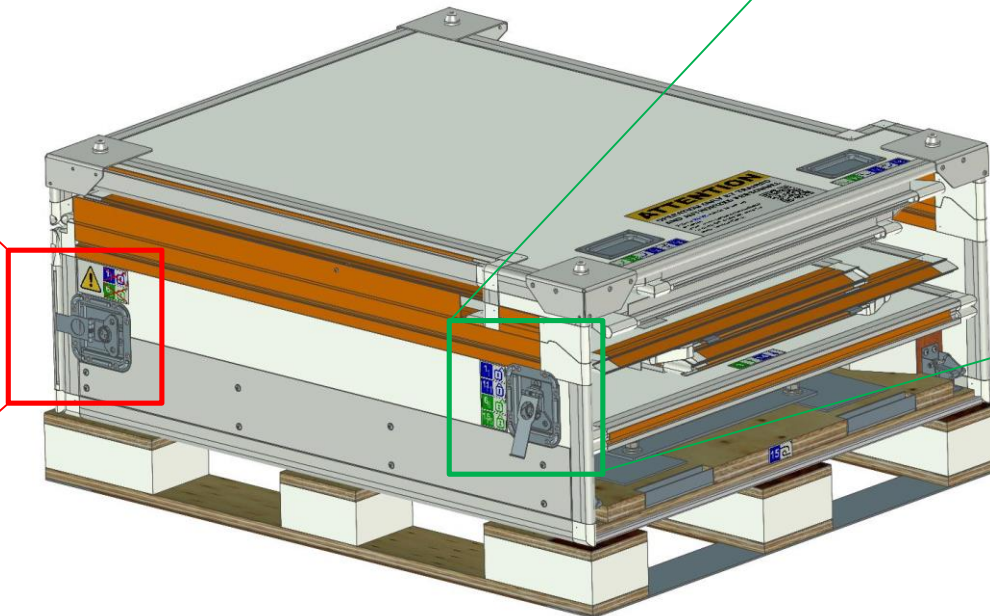
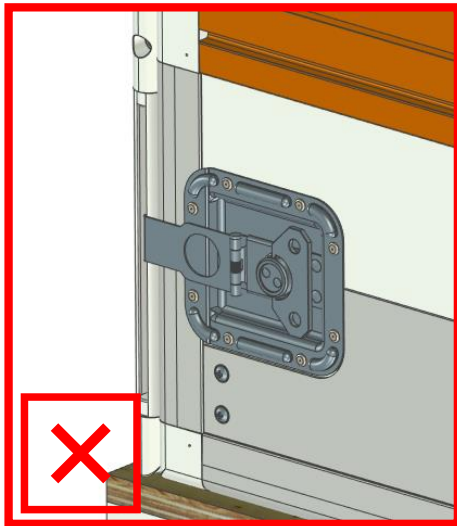

# 2

## RACKPAK SETUP INSTRUCTIONS



Open to an angle of 90°.

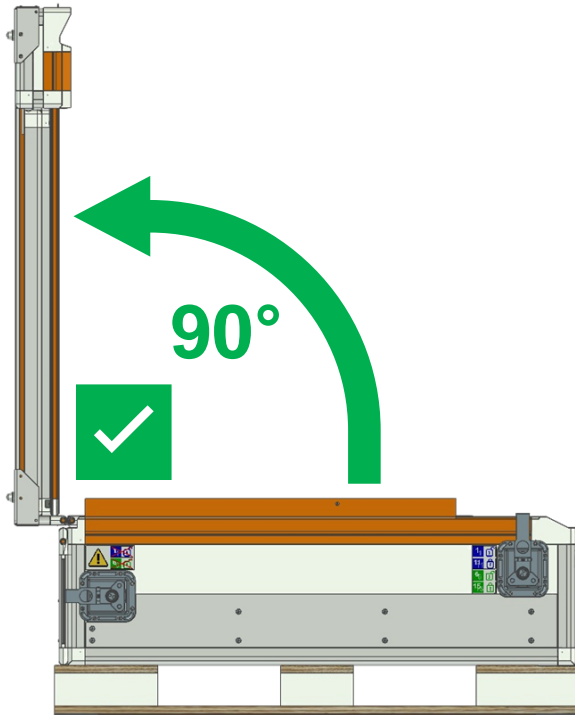

Do not open more than 90°!

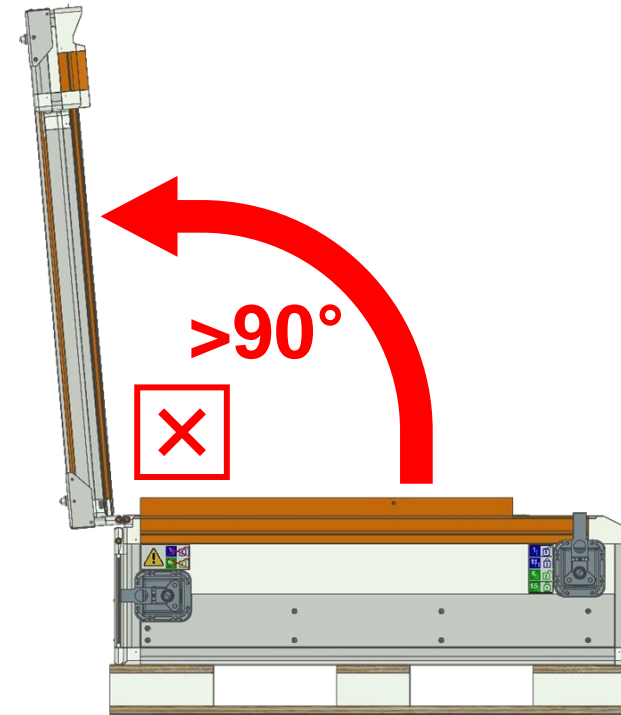

# 3

## RACKPAK SETUP INSTRUCTIONS



Open the first panel by pulling the handle provided.

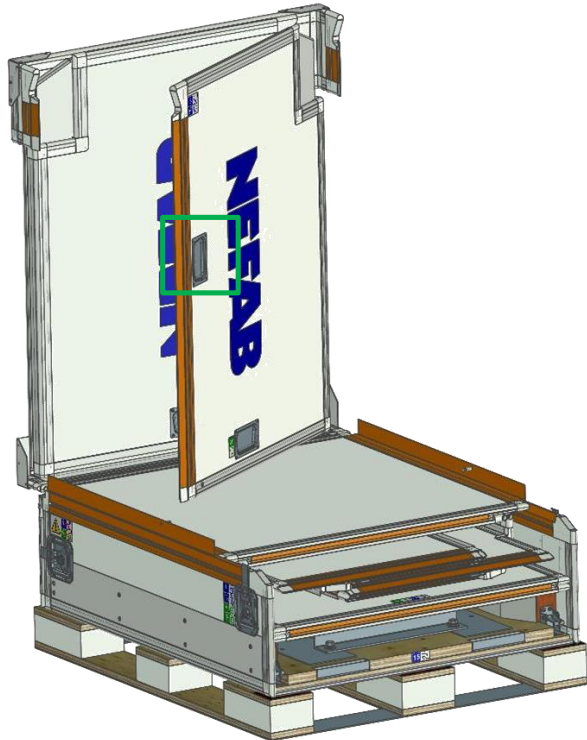

Open 90° until the panel hits the side



# 4

## RACKPAK SETUP INSTRUCTIONS



Close the slide latch, so it clicks in place around the locking pin.

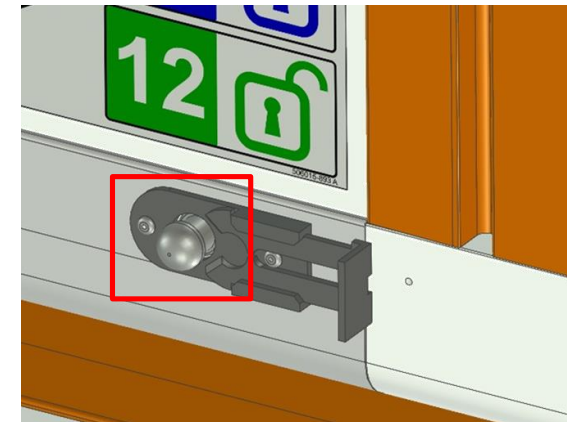
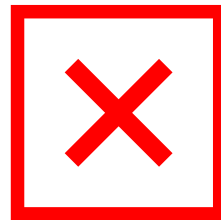
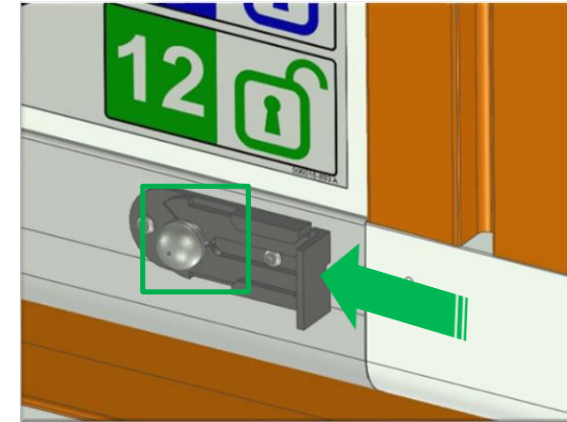

# 5

## RACKPAK SETUP INSTRUCTIONS



Open the second panel by pulling the handle provided.

Open 90° until the panel hits the side

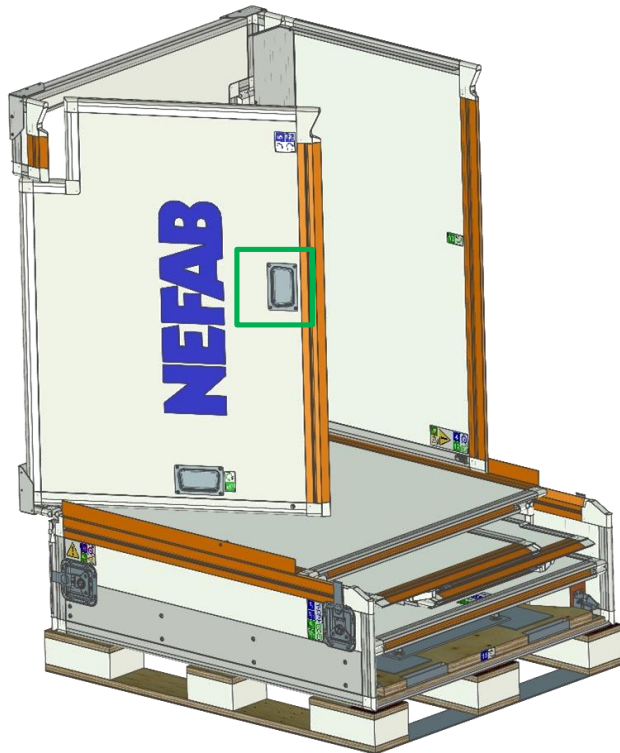

# 6

## RACKPAK SETUP INSTRUCTIONS



Lock the panel in place just like on the other side.

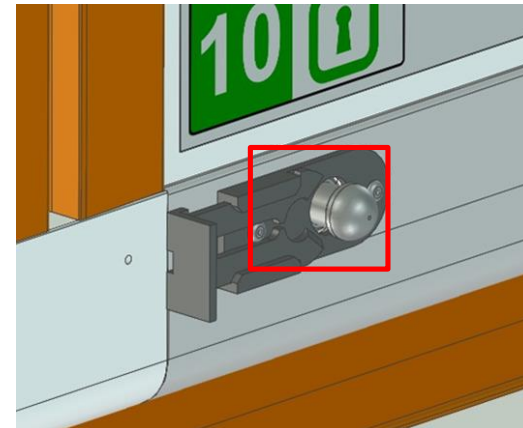
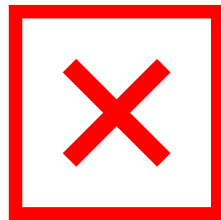
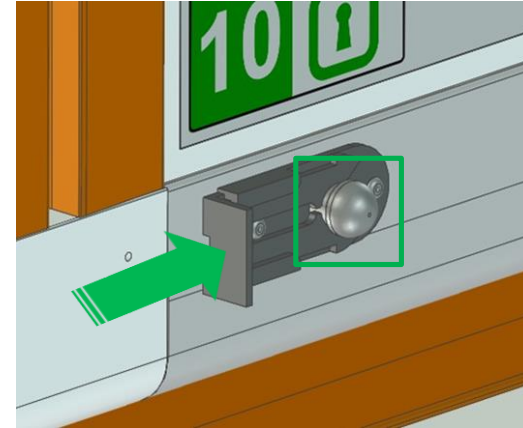

# 7

## RACKPAK SETUP INSTRUCTIONS



Rotate until the front corners of the top section touch the floor behind the product

Then let the top section slide backwards until it sits flat on the floor

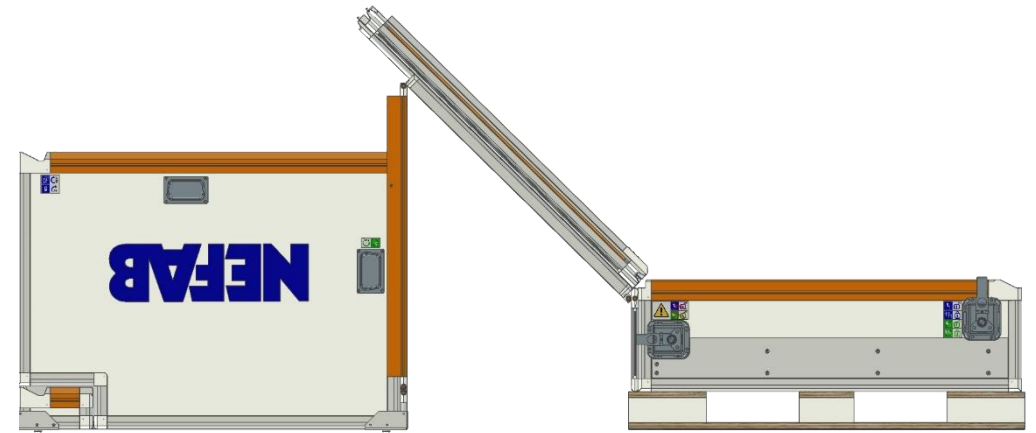
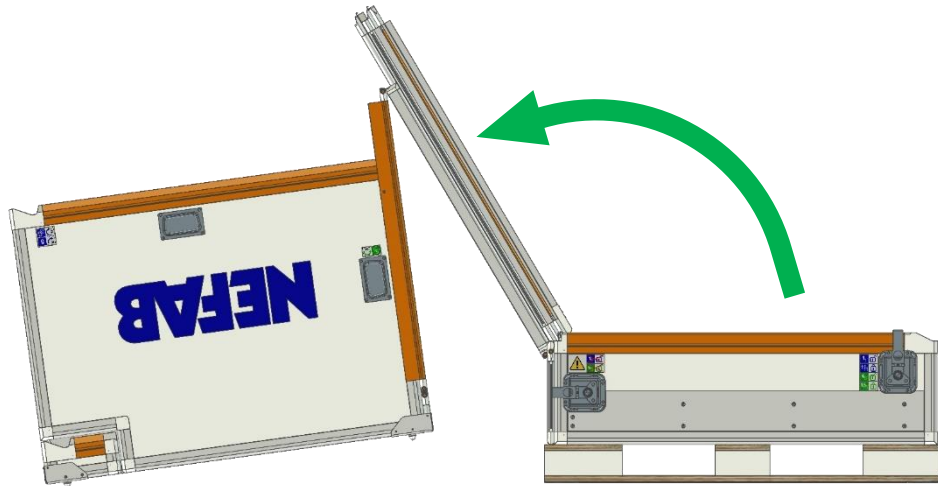

# 8

## RACKPAK SETUP INSTRUCTIONS



Open up the first folded side panel 180° and keep in place

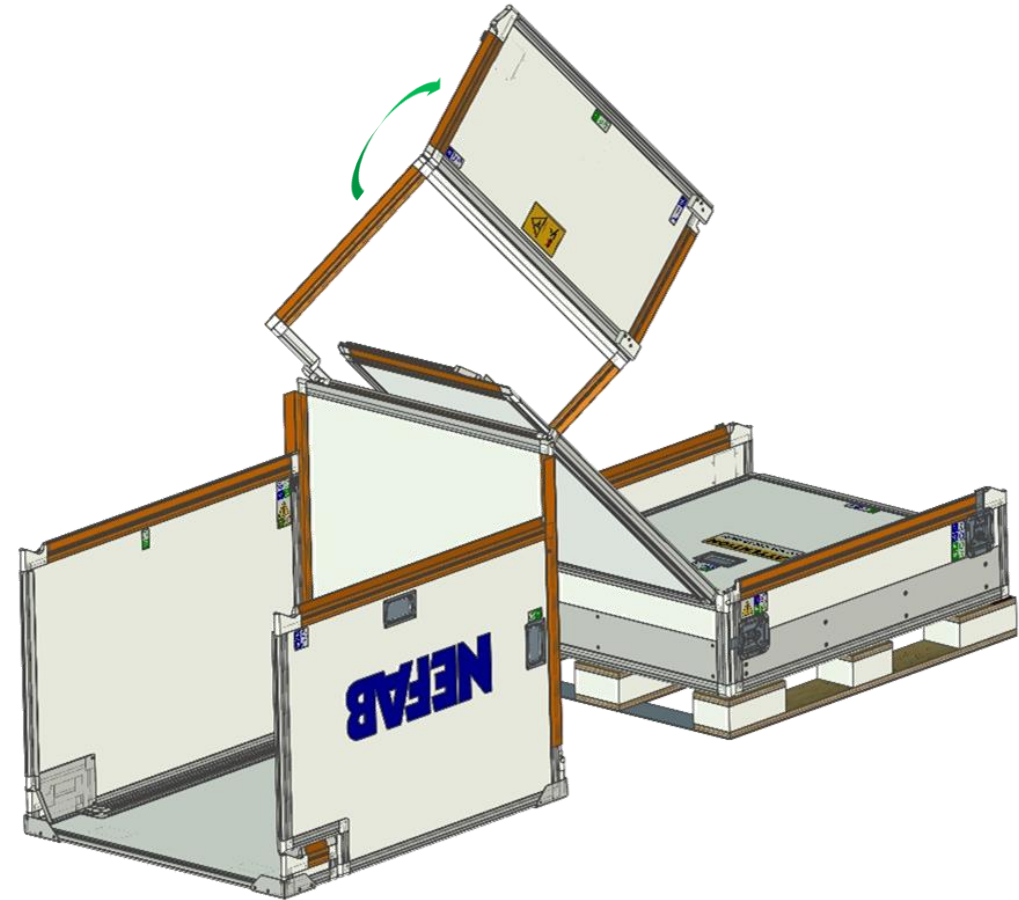



# 9

## RACKPAK SETUP INSTRUCTIONS



Open up the second folded side panel 180° and keep in place

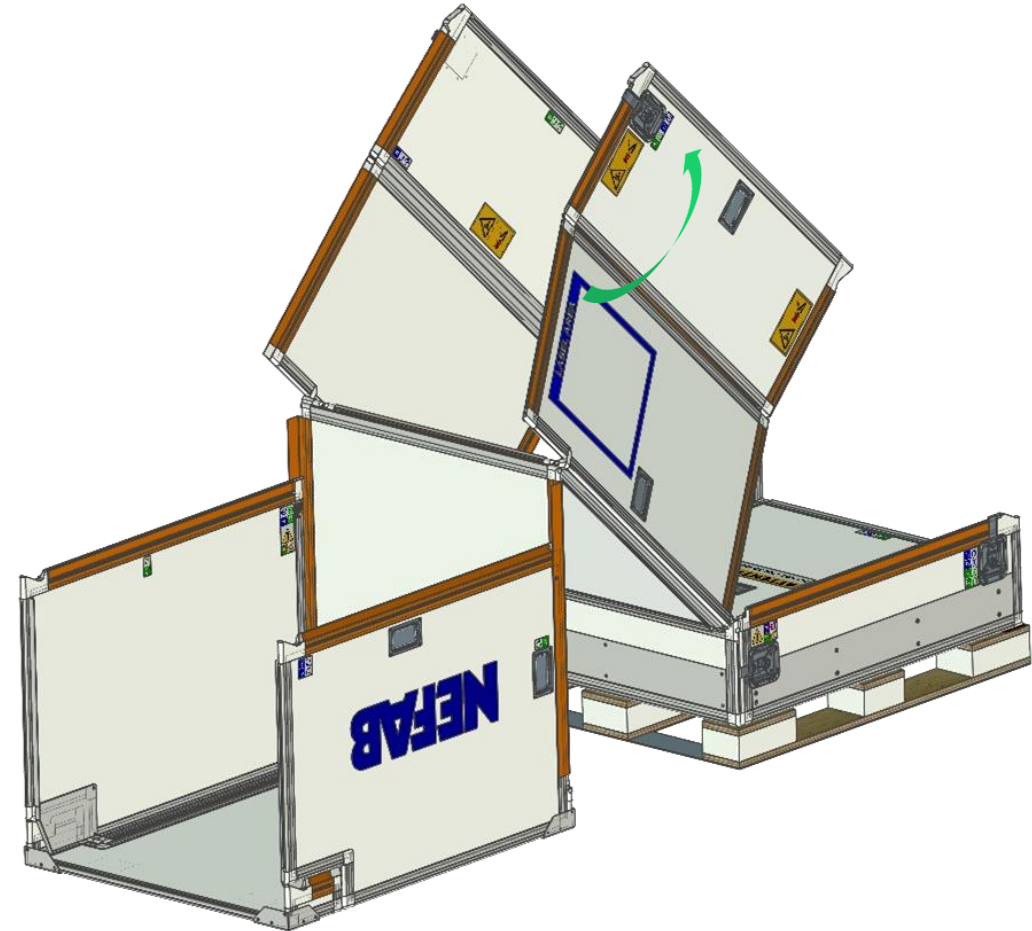

# 10

## RACKPAK SETUP INSTRUCTIONS



Rotate the opened panels downwards so they land in the corresponding base profile.

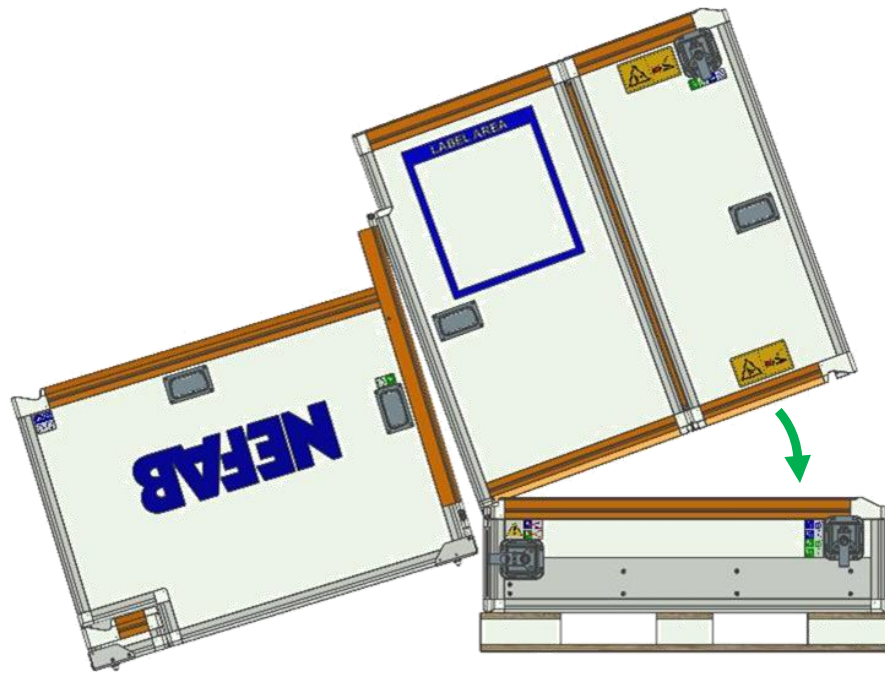

Warning:

Make sure that the profiles fit correctly into each other. Pay special attention to indicated areas.

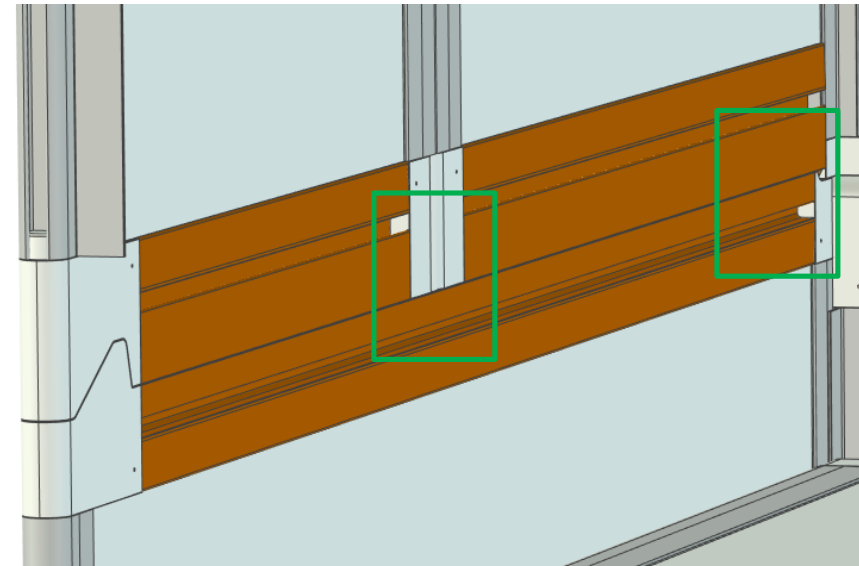

# 11

## RACKPAK SETUP INSTRUCTIONS



Make sure that the front edges of the panels line up.

Then, lock the panels in place by closing the latches.

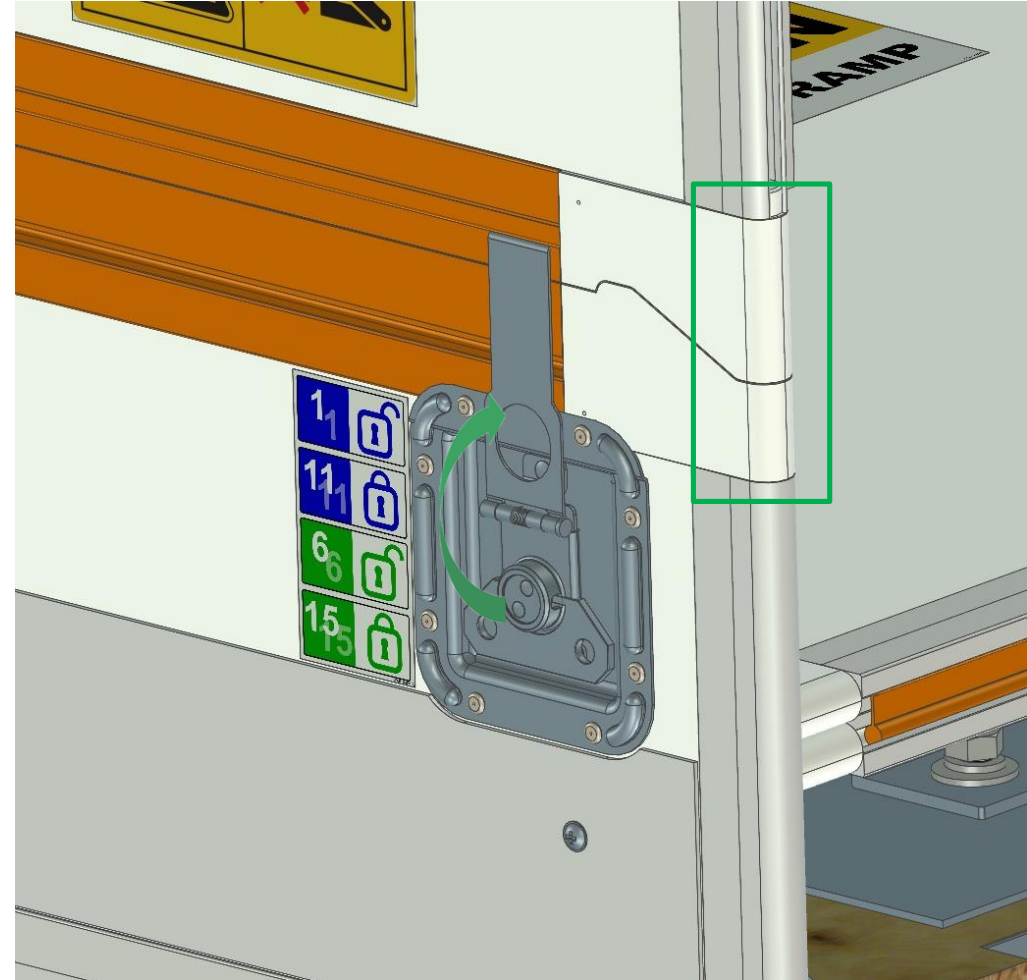

# 12

## RACKPAK SETUP INSTRUCTIONS



Keep rotating upwards.

For the second half of the rotation, it is ok to grab the vertical edges.

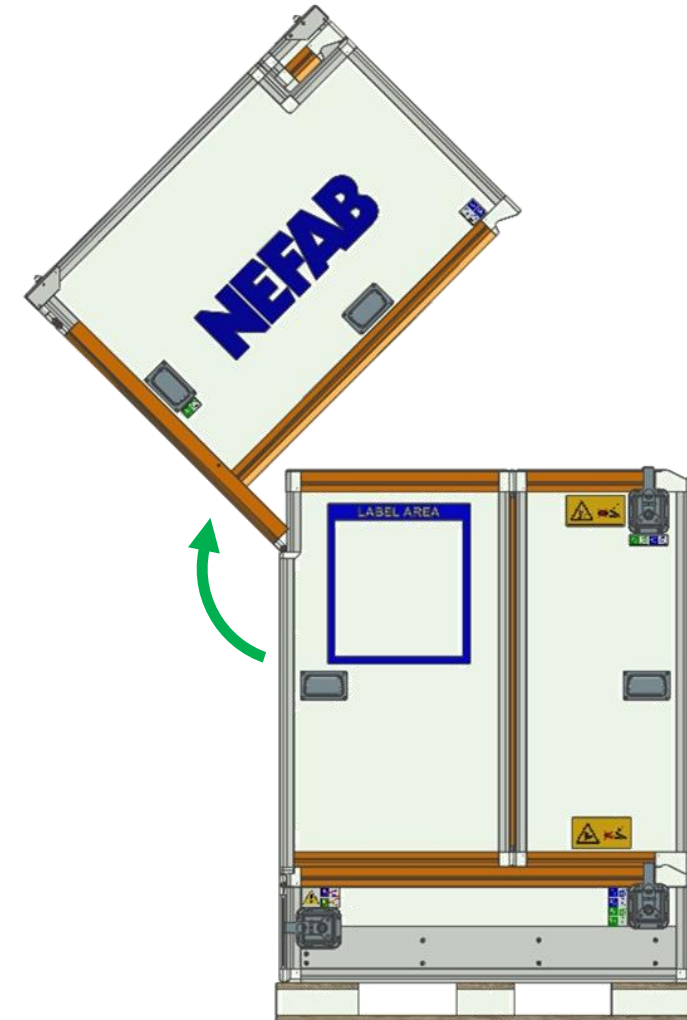

# 13

## RACKPAK SETUP INSTRUCTIONS



Make sure that the front edges of the panels line up. Then, lock the panels in place by closing the latches.

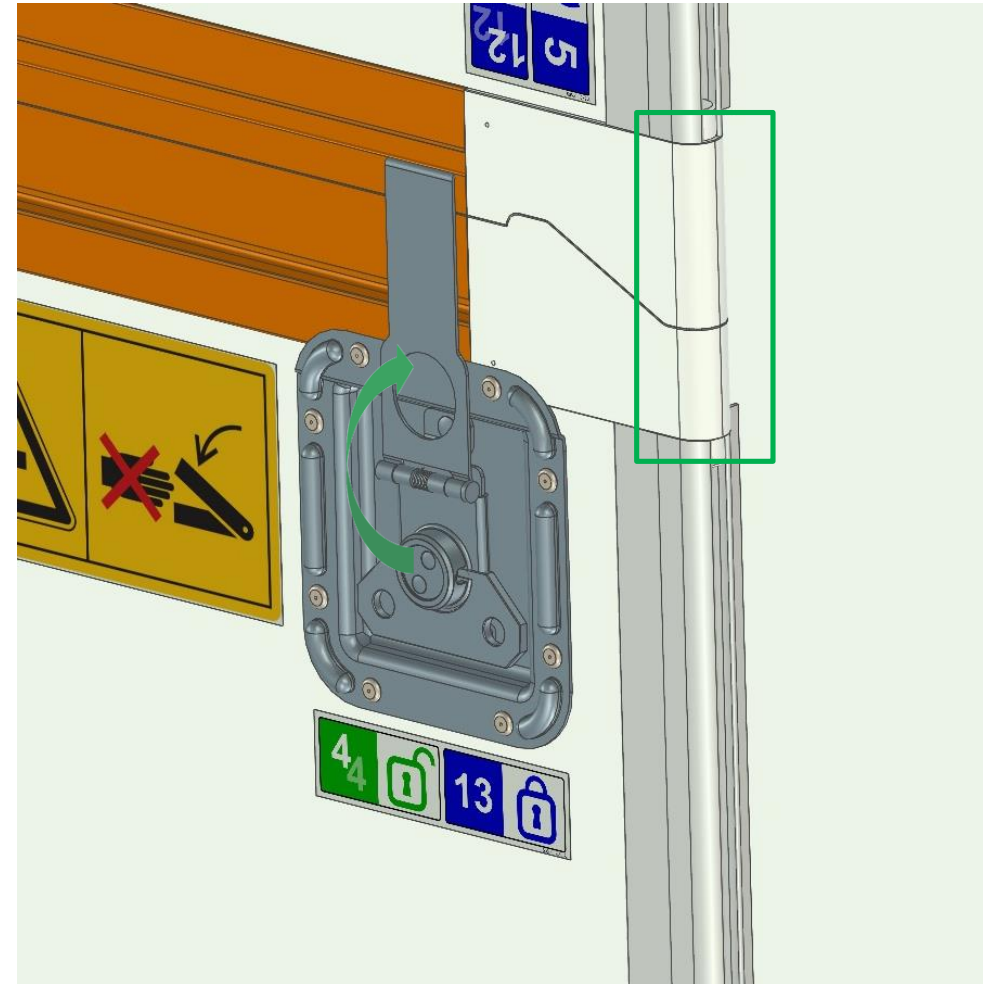

# 14

## RACKPAK SETUP INSTRUCTIONS



Grab the folded front door by the front edge, and pull out of the product base

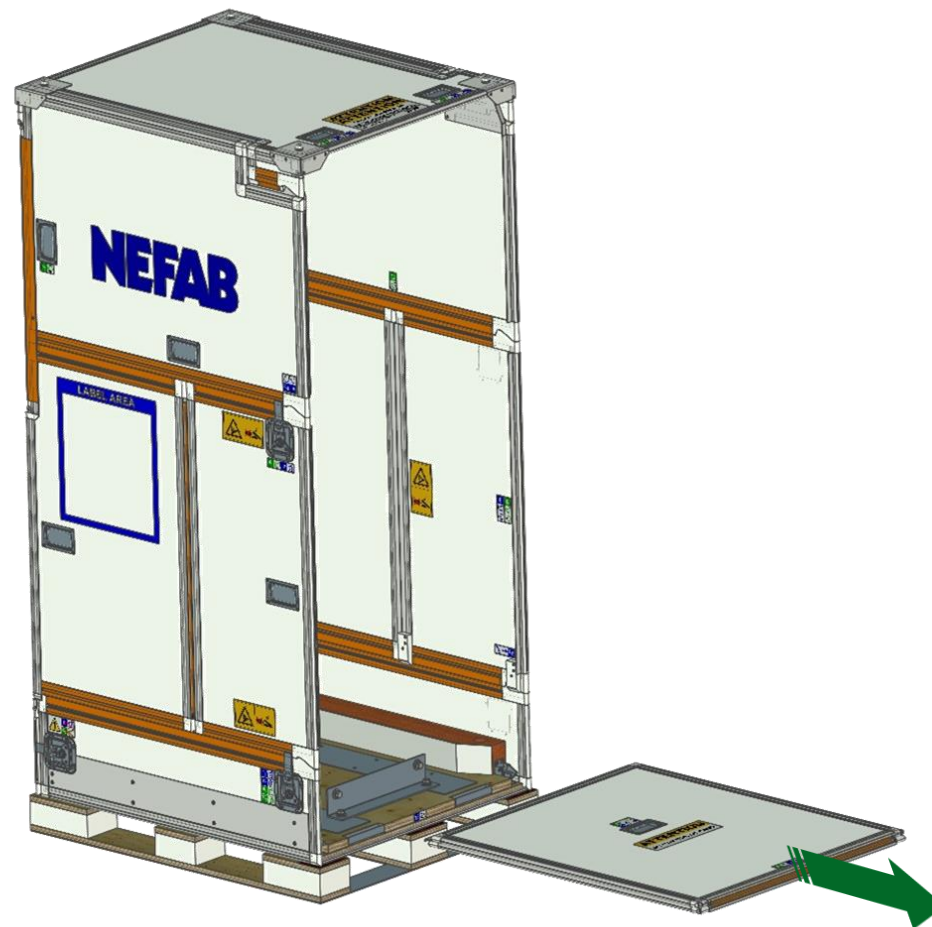

# 15

## RACKPAK SETUP INSTRUCTIONS



Hook the folded front panel into the metal profile at the front edge of the base.

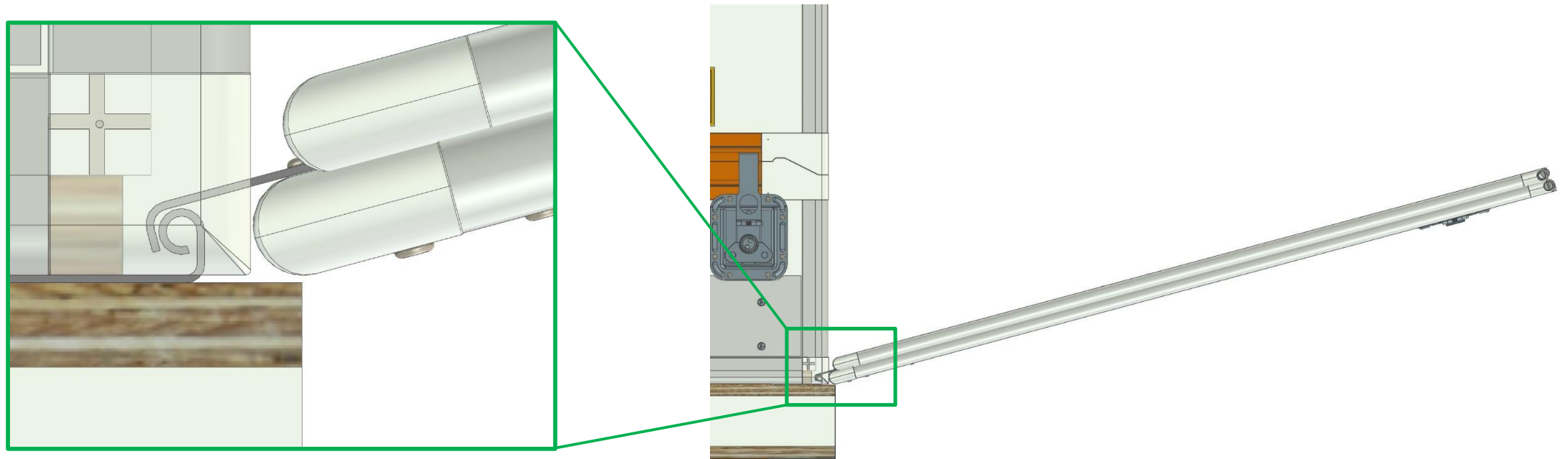

# 16

## RACKPAK SETUP INSTRUCTIONS



Using the handle, raise the front door.

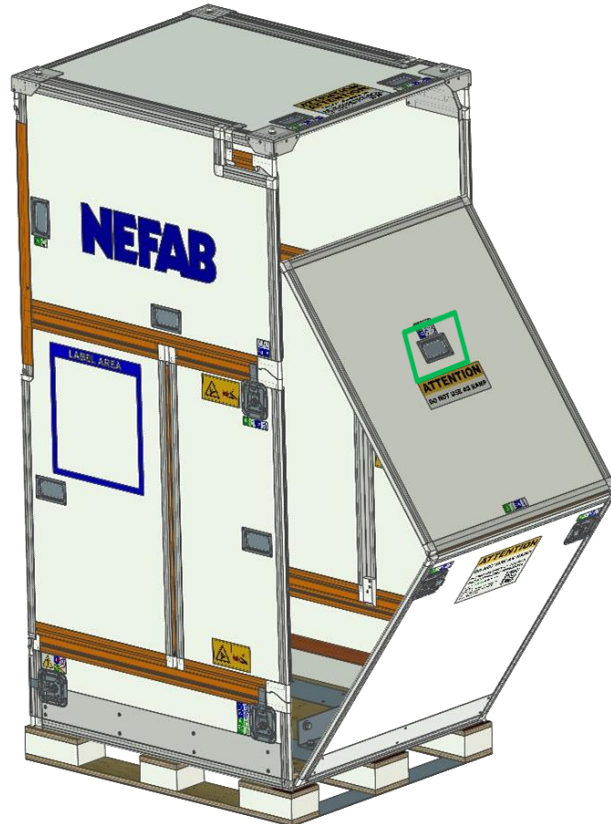

Slide the top corners behind the metal flanges in the upper corners.

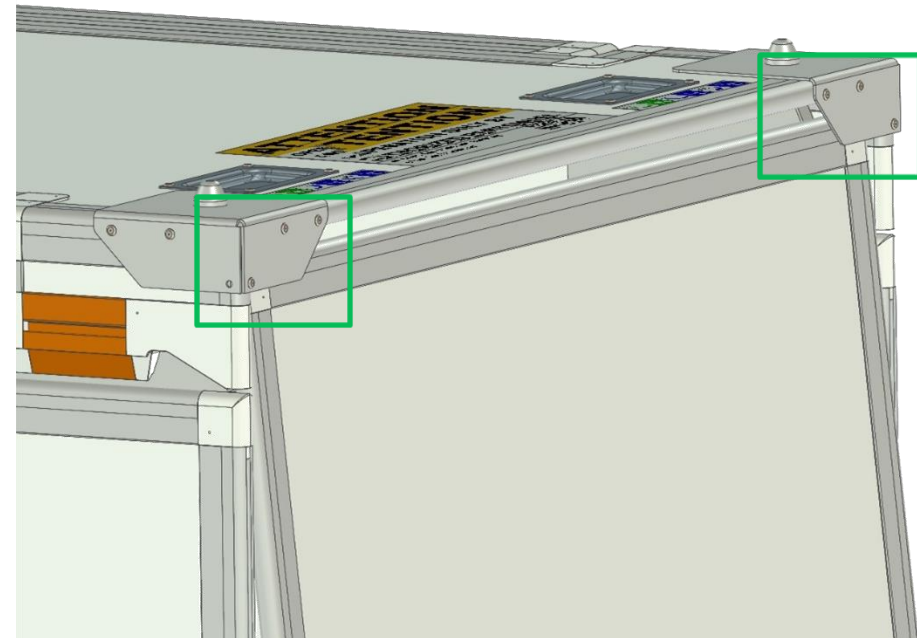



# 17

## RACKPAK SETUP INSTRUCTIONS



Close both latches to secure the front door.

Finished.

